

HLAE

The unique planetary gearbox with certified hygienic design – ideal for reliable cleaning processes

Our **HLAE** is unique: It is the world's first planetary gearbox with certified hygienic design – flexible without a radial screw, powerful, and yet ideal for fast and easy cleaning. It has been developed specifically for challenging applications such as in the pharmaceutical, cosmetics and food industries.

Nominal output torque **15 - 171 Nm**

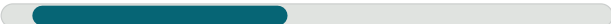

Torsional backlash **7 - 12 arcmin**



Tilting moment **22 - 109 Nm**



Protection class **IP69K**



Frame sizes

70

90

110

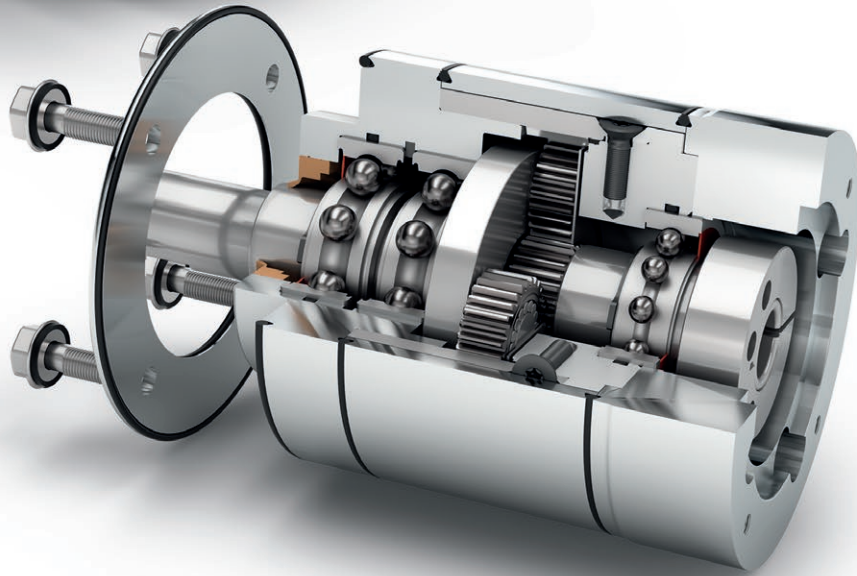
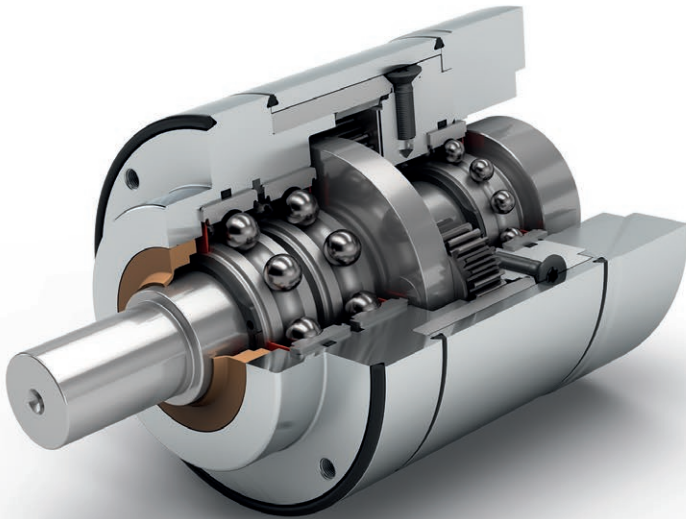

Hygienic Design

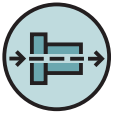

Coaxial gearbox



Spur gear



Low-friction deep groove ball bearings



Planet carrier in disc design



Equidirectional rotation

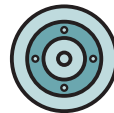

Round type output flange



Rotary shaft seal



Option: FFKM seal

Code	Gearbox characteristics			HLAE070	HLAE090	HLAE110	p ⁽¹⁾	
	Service life (L _{10h})	t _L	h	30,000				
	Efficiency at full load ⁽²⁾	η	%	98			1	
				97			2	
	Min. operating temperature	T _{min}	°C	-25 (-13)				
	Max. operating temperature	T _{max}	(°F)	90 (194)				
	Protection class				IP69K			
F	Food grade lubrication				Grease (lifetime lubrication)			
	Installation position				Any			
S	Standard backlash	j _t	arcmin	< 10	< 7	< 7	1	
				< 12	< 9	< 9	2	
	Torsional stiffness ⁽²⁾	c _g	Nm/arcmin (lb _f .in/ arcmin)	2.3 - 3.1 (20 - 27)	6.6 - 8.7 (58 - 77)	14.7 - 19.5 (130 - 173)	1	
				2.2 - 3.2 (19 - 28)	6.6 - 9.0 (58 - 80)	13.5 - 20.5 (119 - 181)	2	
	Gearbox weight	m _G	kg (lb _m)	2.1 (4.6)	3 (6.6)	8.7 (19.2)	1	
				2.4 (5.3)	3.7 (8.2)	11 (24.3)	2	
S	Standard surface				Housing: Stainless steel 1.4404 – electropolished (R _a < 0,08 μm)			
	Running noise ⁽³⁾	Q _g	dB(A)	58	60	65		
	Max. bending moment based on the gearbox input flange ⁽⁴⁾	M _b	Nm (lb _f .in)	8 (71)	16 (142)	40 (354)		

Output shaft loads			HLAE070	HLAE090	HLAE110	p ⁽¹⁾
Radial force for 20,000 h ⁽⁵⁾⁽⁶⁾	F _{r 20.000 h}	N (lb _f)	450 (101)	900 (202)	1450 (326)	
Axial force for 20,000 h ⁽⁵⁾⁽⁶⁾	F _{a 20.000 h}		550 (124)	1500 (337)	2500 (562)	
Radial force for 30,000 h ⁽⁵⁾⁽⁶⁾	F _{r 30.000 h}		400 (90)	600 (135)	1250 (281)	
Axial force for 30,000 h ⁽⁵⁾⁽⁶⁾	F _{a 30.000 h}		500 (112)	1000 (225)	2000 (450)	
Maximum radial force ⁽⁶⁾⁽⁷⁾	F _{r Stat}		1000 (225)	1250 (281)	5000 (1124)	
Maximum axial force ⁽⁶⁾⁽⁷⁾	F _{a Stat}		1200 (270)	1600 (360)	3800 (854)	
Tilting moment for 20,000 h ⁽⁵⁾⁽⁷⁾	M _{K 20.000 h}	Nm (lb _f .in)	22 (195)	49 (434)	109 (965)	
Tilting moment for 30,000 h ⁽⁵⁾⁽⁷⁾	M _{K 30.000 h}		19 (168)	33 (292)	94 (832)	

Moment of inertia			HLAE070	HLAE090	HLAE110	p ⁽¹⁾
Mass moment of inertia ⁽²⁾	J	kgcm ² (lb _f .in.s ² 10 ⁻⁴)	0.065 - 0.135 (0.575 - 1.195)	0.753 - 0.866 (6.665 - 7.665)	1.579 - 2.630 (13.975 - 23.277)	1
			0.064 - 0.131 (0.566 - 1.159)	0.740 - 0.983 (6.550 - 8.700)	1.569 - 2.620 (13.887 - 23.189)	2

⁽¹⁾ Number of stages

⁽²⁾ The ratio-dependent values can be retrieved in Tec Data Finder – www.neugart.com

⁽³⁾ Sound pressure level from 1 m, measured on input running at n_i=3000 rpm no load; i=5

⁽⁴⁾ Max. motor weight* in kg = 0.2 × M_b / motor length in m
* with symmetrically distributed motor weight
* with horizontal and stationary mounting

⁽⁵⁾ These values are based on an output shaft speed of n₂=100 rpm

⁽⁶⁾ Based on center of output shaft

⁽⁷⁾ Other (sometimes higher) values following changes to T_{2N}, F_r, F_a, cycle, and service life of bearing. Application specific configuration with NCP – www.neugart.com

Output torques			HLAE070	HLAE090	HLAE110	i ⁽¹⁾	p ⁽²⁾				
Nominal output torque ⁽³⁾⁽⁴⁾	T _{2N}	Nm (lb _r .in)	28 (248)	85 (752)	115 (1018)	3	1				
			33 (292)	87 (770)	155 (1372)	4					
			30 (266)	82 (726)	171 (1513)	5					
			25 (221)	65 (575)	135 (1195)	7					
			18 (159)	50 (443)	120 (1062)	8					
			15 (133)	38 (336)	95 (841)	10					
			33 (292)	87 (770)	157 (1390)	9	2				
			33 (292)	80 (708)	171 (1513)	12					
			33 (292)	82 (726)	171 (1513)	15					
			33 (292)	87 (770)	171 (1513)	16					
			33 (292)	87 (770)	171 (1513)	20					
			30 (266)	82 (726)	171 (1513)	25					
			33 (292)	87 (770)	171 (1513)	32					
			30 (266)	82 (726)	171 (1513)	40					
			18 (159)	50 (443)	120 (1062)	64					
			15 (133)	38 (336)	95 (841)	100					
			Max. output torque ⁽⁴⁾⁽⁵⁾	T _{2max}	Nm (lb _r .in)	45 (398)		136 (1204)	184 (1629)	3	1
						53 (469)		140 (1239)	248 (2195)	4	
48 (425)	131 (1159)	274 (2425)				5					
40 (354)	104 (920)	216 (1912)				7					
29 (257)	80 (708)	192 (1699)				8					
24 (212)	61 (540)	152 (1345)				10					
53 (469)	140 (1239)	251 (2222)				9	2				
53 (469)	140 (1239)	274 (2425)				12					
53 (469)	131 (1159)	274 (2425)				15					
53 (469)	140 (1239)	274 (2425)				16					
53 (469)	140 (1239)	274 (2425)				20					
48 (425)	131 (1159)	274 (2425)				25					
53 (469)	140 (1239)	274 (2425)				32					
48 (425)	131 (1159)	274 (2425)				40					
29 (257)	80 (708)	192 (1699)				64					
24 (212)	61 (540)	152 (1345)				100					

⁽¹⁾ Ratios (i=n₁/n₂)

⁽²⁾ Number of stages

⁽³⁾ Application specific configuration with NCP – www.neugart.com

⁽⁴⁾ Values for feather key (code "A"): for repeated load

⁽⁵⁾ 30,000 rotations of the output shaft permitted; see page 142

Output torques			HLAE070	HLAE090	HLAE110	$i^{(1)}$	$p^{(2)}$
Emergency stop torque ⁽³⁾	T_{2Stop}	Nm (lb _f .in)	56 (496)	170 (1505)	230 (2036)	3	1
			66 (584)	174 (1540)	310 (2744)	4	
			60 (531)	164 (1452)	342 (3027)	5	
			50 (443)	130 (1151)	270 (2390)	7	
			36 (319)	100 (885)	240 (2124)	8	
			30 (266)	76 (673)	190 (1682)	10	
			66 (584)	174 (1540)	314 (2779)	9	2
			66 (584)	174 (1540)	342 (3027)	12	
			66 (584)	164 (1452)	342 (3027)	15	
			66 (584)	174 (1540)	342 (3027)	16	
			66 (584)	174 (1540)	342 (3027)	20	
			60 (531)	164 (1452)	342 (3027)	25	
			66 (584)	174 (1540)	342 (3027)	32	
			60 (531)	164 (1452)	342 (3027)	40	
			36 (319)	100 (885)	240 (2124)	64	
			30 (266)	76 (673)	190 (1682)	100	

Input speeds			HLAE070	HLAE090	HLAE110	$i^{(1)}$	$p^{(2)}$
Average thermal input speed at T_{2N} and S1 ⁽⁴⁾⁽⁵⁾	n_{1N}	rpm	3000	2500	2000	3	1
			3000	2500	2000	4	
			3000	2500	2000	5	
			3000	2500	2000	7	
			3000	2500	2000	8	
			3000	2500	2000	10	
			3500	3000	2500	9	2
			3500	3000	2500	12	
			3500	3000	2500	15	
			3500	3000	2500	16	
			3500	3000	2500	20	
			3500	3000	2500	25	
			3500	3000	2500	32	
			3500	3000	2500	40	
			3500	3000	2500	64	
			3500	3000	2500	100	
			Max. mechanical input speed ⁽⁴⁾	n_{1Limit}	rpm	13000	

⁽¹⁾ Ratios ($i=n_1/n_2$)

⁽²⁾ Number of stages

⁽³⁾ Permitted 1000 times

⁽⁴⁾ Application-specific speed configurations with NCP – www.neugart.com
⁽⁵⁾ See page 142 for the definition

⁽⁶⁾ Average thermal input speed at 50% T_{2N} and S1

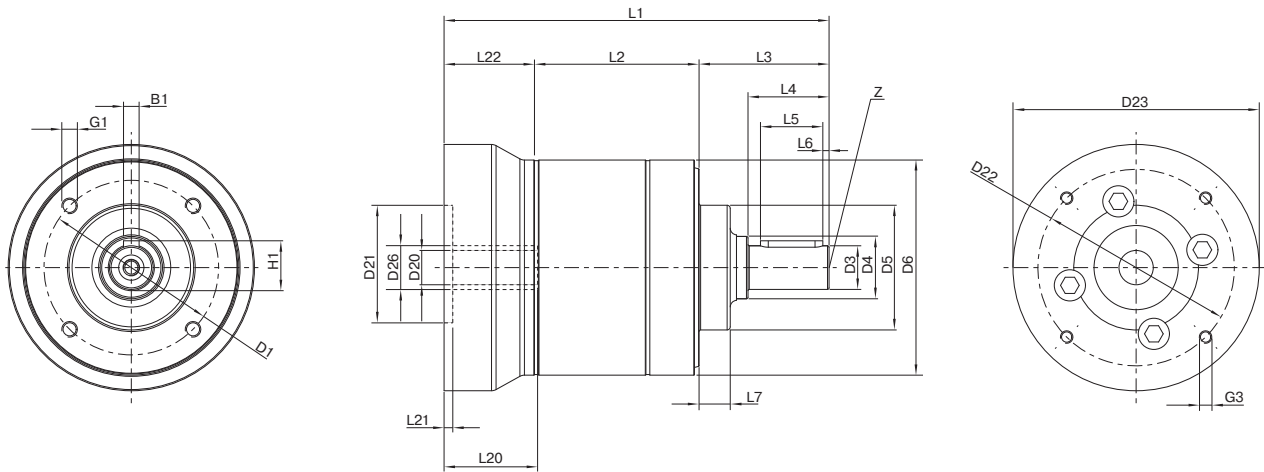

Drawing corresponds to a HLAE070 / 1-stage / output shaft with feather key / 11 mm clamping system / motor adaptation – one part / B5 flange type motor
 All other variants can be retrieved in the Tec Data Finder at www.neugart.com

Geometry ⁽¹⁾			HLAE070	HLAE090	HLAE110	z ⁽²⁾	Code	
Pitch circle diameter output	D1		56 (2.205)	75 (2.953)	90 (3.543)			
Shaft diameter output	D3	h7	14 (0.551)	20 (0.787)	25 (0.984)			
Shaft collar output	D4		20 (0.787)	25 (0.984)	35 (1.378)			
Centering diameter output	D5	h7	40 (1.575)	58 (2.283)	65 (2.559)			
Housing diameter	D6		69 (2.717)	88 (3.465)	109 (4.291)			
Mounting thread x depth	G1	4x	M5x11	M6x12	M8x20			
Min. total length	L1		123.5 (4.862)	146 (5.748)	191 (7.520)	1		
			135.5 (5.335)	166 (6.535)	219 (8.622)	2		
Housing length	L2		52.8 (2.079)	68.0 (2.677)	89.0 (3.504)	1		
			64.8 (2.551)	88.0 (3.465)	117.0 (4.606)	2		
Shaft length output	L3		41.7 (1.642)	50 (1.969)	66.5 (2.618)			
Centering depth output	L7		10 (0.394)	13 (0.512)	14 (0.551)			
Clamping system diameter input	D26		More information on page 131					
Motor shaft diameter j6/k6	D20		The dimensions vary with the motor/gearbox flange. The input flange dimensions can be retrieved for each specific motor in Tec Data Finder at www.neugart.com					
Max. permis. motor shaft length	L20							
Min. permis. motor shaft length								
Centering diameter input	D21							
Centering depth input	L21							
Pitch circle diameter input	D22							
Motor flange length	L22							
Diagonal dimension input	D23							
Mounting thread x depth	G3	4x						
Output shaft with feather key (DIN 6885-1)						A 5x5x20	A 6x6x25	A 8x7x35
Feather key width (DIN 6885-1)	B1		5 (0.197)	6 (0.236)	8 (0.315)			
Shaft height including feather key (DIN 6885-1)	H1		16 (0.630)	22.5 (0.886)	28 (1.102)			
Shaft length from shoulder	L4		26 (1.024)	32 (1.260)	45 (1.772)			
Feather key length	L5		20 (0.787)	25 (0.984)	35 (1.378)			
Distance from shaft end	L6		2 (0.079)	2.5 (0.098)	5 (0.197)			
Center hole (DIN 332, type DR)	Z		M5x12.5	M6x16	M10x22			
Smooth output shaft							B	
Shaft length from shoulder	L4		26 (1.024)	32 (1.260)	45 (1.772)			

⁽¹⁾ Dimensions in mm (in)

⁽²⁾ Number of stages