

PLN

The perfectly sealed planetary gearbox with straight gearing delivers the maximum performance without ever losing the required stiffness

Our straight-toothed precision planetary gearbox has been designed for the highest performance and torque. The prestressed tapered roller bearings in the **PLN** and the seal we have developed safeguard the optimal performance even against dust and water jets.

Nominal output torque **27 - 1800 Nm**

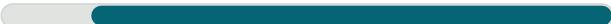

Torsional backlash **1 - 5 arcmin**



Tilting moment **191 - 2535 Nm**



Protection class **IP65**



Frame sizes

- 70
- 90
- 115
- 142
- 190

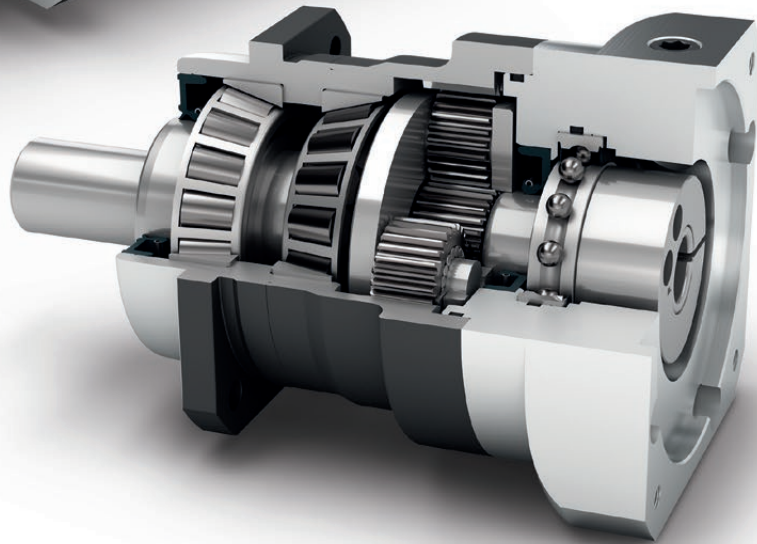
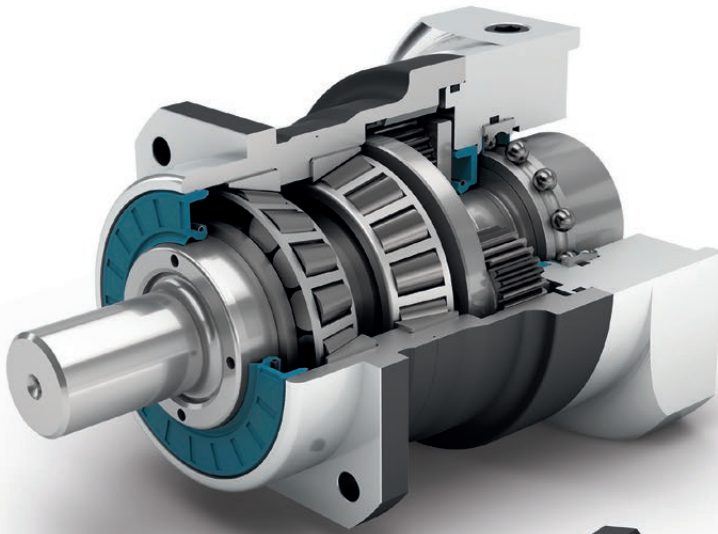

Precision Line



Coaxial gearbox



Spur gear



Preloaded tapered roller bearings



Extra long centering collar



Option: Reduced backlash



Equidirectional rotation



Square type output flange



Rotary shaft seal



Planet carrier in cage design



Option: Splined output shaft (DIN 5480)

Code	Gearbox characteristics			PLN070	PLN090	PLN115	PLN142	PLN190	p ⁽¹⁾
	Service life (L _{10h})	t _L	h	20,000					
	Service life at T _{2N} x 0.88			30,000					
	Efficiency at full load ⁽²⁾	η	%	98					1
				95					2
	Min. operating temperature	T _{min}	°C (°F)	-25 (-13)					
	Max. operating temperature	T _{max}		90 (194)					
	Protection class				IP65				
S	Standard lubrication				Oil (lifetime lubrication)				
F	Food grade lubrication				Oil (lifetime lubrication)				
L	Low temperature lubrication ⁽³⁾				Oil (lifetime lubrication)				
	Installation position				Any				
S	Standard backlash	j _t	arcmin	< 3					1
R	Reduced backlash			< 5					2
	Torsional stiffness ⁽²⁾	c _g	Nm/arcmin (lb _t .in/ arcmin)	3.4 - 5.0 (30 - 44)	9.4 - 12.4 (83 - 110)	22.0 - 29.0 (195 - 257)	61.0 - 76.0 (540 - 673)	155.0 - 218.0 (1372 - 1929)	1
					3.4 - 5.0 (30 - 44)	9.0 - 12.4 (80 - 110)	22.5 - 29.5 (199 - 261)	61.0 - 78.0 (540 - 690)	169.0 - 224.0 (1496 - 1983)
	Gearbox weight	m _G	kg (lb _m)	1.9 (4.2)	3.3 (7.3)	6.9 (15.2)	16 (35.3)	30.5 (67.3)	1
					2.4 (5.3)	4.2 (9.3)	9.5 (21.0)	20.5 (45.2)	45 (99.2)
S	Standard surface				Housing: Steel – heat-treated and post-oxidized (black)				
	Running noise ⁽⁴⁾	Q _g	dB(A)	60	62	65	70	74	
	Max. bending moment based on the gearbox input flange ⁽⁵⁾	M _b	Nm (lb _t .in)	18 (159)	38 (336)	80 (708)	180 (1593)	300 (2655)	

Output shaft loads			PLN070	PLN090	PLN115	PLN142	PLN190	p ⁽¹⁾
Radial force for 20,000 h ⁽⁶⁾⁽⁷⁾	F _{r,20.000h}	N (lb _f)	3200 (719)	5500 (1236)	6000 (1349)	12500 (2810)	21000 (4721)	
Axial force for 20,000 h ⁽⁶⁾⁽⁷⁾	F _{a,20.000h}		4400 (989)	6400 (1439)	8000 (1798)	15000 (3372)	21000 (4721)	
Radial force for 30,000 h ⁽⁶⁾⁽⁷⁾	F _{r,30.000h}		3200 (719)	4800 (1079)	5400 (1214)	11400 (2563)	18000 (4047)	
Axial force for 30,000 h ⁽⁶⁾⁽⁷⁾	F _{a,30.000h}		3900 (877)	5700 (1281)	7000 (1574)	13200 (2967)	18500 (4159)	
Maximum radial force ⁽⁷⁾⁽⁸⁾	F _{r,Stat}		3200 (719)	5500 (1236)	6000 (1349)	12500 (2810)	21000 (4721)	
Maximum axial force ⁽⁷⁾⁽⁸⁾	F _{a,Stat}		4400 (989)	6400 (1439)	8000 (1798)	15000 (3372)	21000 (4721)	
Tilting moment for 20,000 h ⁽⁶⁾⁽⁸⁾	M _{K,20.000h}	Nm (lb _t .in)	191 (1690)	383 (3390)	488 (4319)	1420 (12568)	2535 (22437)	
Tilting moment for 30,000 h ⁽⁶⁾⁽⁸⁾	M _{K,30.000h}		191 (1690)	335 (2965)	439 (3885)	1295 (11462)	2173 (19233)	

Moment of inertia			PLN070	PLN090	PLN115	PLN142	PLN190	p ⁽¹⁾
Mass moment of inertia ⁽²⁾	J	kgcm ² (lb _t .in.s ² 10 ⁻⁴)	0,216 - 0,365 (1.912 - 3.231)	0,560 - 1,028 (4.956 - 9.099)	1,942 - 3,256 (17.188 - 28.818)	7,008 - 15,270 (62.026 - 135.151)	22,876 - 63,815 (202.470 - 564.810)	1
			0,209 - 0,249 (1.850 - 2.204)	0,544 - 0,699 (4.815 - 6.187)	1,933 - 2,373 (17.108 - 21.003)	6,811 - 9,813 (60.282 - 86.852)	22,430 - 36,003 (198.522 - 318.653)	2

(1) Number of stages
(2) The ratio-dependent values can be retrieved in Tec Data Finder – www.neugart.com
(3) T_{min} = -40°C. Optimal operating temperature max. 50°C
(4) Sound pressure level from 1 m, measured on input running at n₁=3000 rpm no load; i=5
(5) Max. motor weight* in kg = 0.2 x M_b / motor length in m
* with symmetrically distributed motor weight
* with horizontal and stationary mounting
(6) These values are based on an output shaft speed of n₂=100 rpm
(7) Based on center of output shaft
(8) Other (sometimes higher) values following changes to T_{2N}, F_r, F_a, cycle, and service life of bearing. Application specific configuration with NCP – www.neugart.com

Output torques			PLN070	PLN090	PLN115	PLN142	PLN190	i ⁽¹⁾	p ⁽²⁾
Nominal output torque ⁽³⁾⁽⁴⁾	T _{2N}	Nm (lb _f .in)	45 (398)	100 (885)	230 (2036)	450 (3983)	1000 (8851)	3	1
			60 (531)	140 (1239)	300 (2655)	600 (5310)	1300 (11506)	4	
			65 (575)	140 (1239)	260 (2301)	750 (6638)	1600 (14161)	5	
			45 (398)	90 (797)	180 (1593)	530 (4691)	1300 (11506)	7	
			40 (354)	80 (708)	150 (1328)	450 (3983)	1000 (8851)	8	
			27 (239)	60 (531)	125 (1106)	305 (2699)	630 (5576)	10	
			68 (602)	110 (974)	250 (2213)	780 (6904)	1500 (13276)	12	2
			68 (602)	110 (974)	250 (2213)	780 (6904)	1500 (13276)	15	
			77 (682)	150 (1328)	300 (2655)	1000 (8851)	1800 (15931)	16	
			77 (682)	150 (1328)	300 (2655)	1000 (8851)	1800 (15931)	20	
			65 (575)	140 (1239)	260 (2301)	900 (7966)	1800 (15931)	25	
			77 (682)	150 (1328)	300 (2655)	1000 (8851)	1800 (15931)	32	
			65 (575)	140 (1239)	260 (2301)	900 (7966)	1800 (15931)	40	
			40 (354)	80 (708)	150 (1328)	450 (3983)	1000 (8851)	64	
27 (239)	60 (531)	125 (1106)	305 (2699)	630 (5576)	100				
Max. output torque ⁽⁴⁾⁽⁵⁾	T _{2max}	Nm (lb _f .in)	72 (637)	160 (1416)	368 (3257)	720 (6373)	1600 (14161)	3	1
			96 (850)	224 (1983)	480 (4248)	960 (8497)	2080 (18410)	4	
			104 (920)	224 (1983)	416 (3682)	1200 (10621)	2560 (22658)	5	
			72 (637)	144 (1275)	288 (2549)	848 (7505)	2080 (18410)	7	
			64 (566)	128 (1133)	240 (2124)	720 (6373)	1600 (14161)	8	
			43 (381)	96 (850)	200 (1770)	488 (4319)	1008 (8922)	10	
			109 (965)	176 (1558)	400 (3540)	1248 (11046)	2400 (21242)	12	2
			109 (965)	176 (1558)	400 (3540)	1248 (11046)	2400 (21242)	15	
			123 (1089)	240 (2124)	480 (4248)	1600 (14161)	2880 (25490)	16	
			123 (1089)	240 (2124)	480 (4248)	1600 (14161)	2880 (25490)	20	
			104 (920)	224 (1983)	416 (3682)	1440 (12745)	2880 (25490)	25	
			123 (1089)	240 (2124)	480 (4248)	1600 (14161)	2880 (25490)	32	
			104 (920)	224 (1983)	416 (3682)	1440 (12745)	2880 (25490)	40	
			64 (566)	128 (1133)	240 (2124)	720 (6373)	1600 (14161)	64	
43 (381)	96 (850)	200 (1770)	488 (4319)	1008 (8922)	100				

(1) Ratios (i=n₁/n₂)
 (2) Number of stages
 (3) Application specific configuration with NCP – www.neugart.com
 (4) Values for feather key (code "A"): for repeated load
 (5) 30,000 rotations of the output shaft permitted; see page 142

Output torques			PLN070	PLN090	PLN115	PLN142	PLN190	$i^{(1)}$	$p^{(2)}$
Emergency stop torque ⁽³⁾	T_{2Stop}	Nm (lb _f .in)	90 (797)	210 (1859)	490 (4337)	975 (8629)	2000 (17701)	3	1
			120 (1062)	280 (2478)	650 (5753)	1300 (11506)	2700 (23897)	4	
			130 (1151)	280 (2478)	650 (5753)	1500 (13276)	3200 (28322)	5	
			80 (708)	175 (1549)	340 (3009)	1300 (11506)	2600 (23012)	7	
			90 (797)	200 (1770)	380 (3363)	1000 (8851)	2600 (23012)	8	
			90 (797)	200 (1770)	480 (4248)	750 (6638)	1350 (11949)	10	
			135 (1195)	220 (1947)	500 (4425)	1500 (13276)	3000 (26552)	12	2
			135 (1195)	220 (1947)	500 (4425)	1500 (13276)	3000 (26552)	15	
			150 (1328)	300 (2655)	650 (5753)	2000 (17701)	3600 (31863)	16	
			150 (1328)	300 (2655)	650 (5753)	2000 (17701)	3600 (31863)	20	
			150 (1328)	300 (2655)	650 (5753)	1800 (15931)	3600 (31863)	25	
			150 (1328)	300 (2655)	650 (5753)	2000 (17701)	3600 (31863)	32	
			150 (1328)	300 (2655)	650 (5753)	1800 (15931)	3600 (31863)	40	
			80 (708)	200 (1770)	380 (3363)	1000 (8851)	2600 (23012)	64	
			80 (708)	200 (1770)	480 (4248)	750 (6638)	1350 (11949)	100	

Input speeds			PLN070	PLN090	PLN115	PLN142	PLN190	$i^{(1)}$	$p^{(2)}$
Average thermal input speed at T_{2N} and $S1^{(4)(5)}$	n_{1N}	rpm	2050 ⁽⁶⁾	1950 ⁽⁶⁾	1500 ⁽⁶⁾	850 ⁽⁶⁾	700 ⁽⁶⁾	3	1
			2300 ⁽⁶⁾	2100 ⁽⁶⁾	1600 ⁽⁶⁾	950 ⁽⁶⁾	750 ⁽⁶⁾	4	
			2650 ⁽⁶⁾	2500 ⁽⁶⁾	2000 ⁽⁶⁾	1050 ⁽⁶⁾	850 ⁽⁶⁾	5	
			3450 ⁽⁶⁾	3550 ⁽⁶⁾	2800 ⁽⁶⁾	1550 ⁽⁶⁾	1200 ⁽⁶⁾	7	
			3800 ⁽⁶⁾	3950 ⁽⁶⁾	3200 ⁽⁶⁾	1800 ⁽⁶⁾	1450 ⁽⁶⁾	8	
			4400 ⁽⁶⁾	4000	3500 ⁽⁶⁾	2250 ⁽⁶⁾	1900 ⁽⁶⁾	10	
			3550 ⁽⁶⁾	3400 ⁽⁶⁾	2450 ⁽⁶⁾	1300 ⁽⁶⁾	1000 ⁽⁶⁾	12	2
			4000 ⁽⁶⁾	4000 ⁽⁶⁾	3000 ⁽⁶⁾	1600 ⁽⁶⁾	1250 ⁽⁶⁾	15	
			3800 ⁽⁶⁾	3550 ⁽⁶⁾	2550 ⁽⁶⁾	1350 ⁽⁶⁾	1050 ⁽⁶⁾	16	
			4300 ⁽⁶⁾	4000 ⁽⁶⁾	3050 ⁽⁶⁾	1600 ⁽⁶⁾	1300 ⁽⁶⁾	20	
			4500 ⁽⁶⁾	4000 ⁽⁶⁾	3400 ⁽⁶⁾	1850 ⁽⁶⁾	1400 ⁽⁶⁾	25	
			4500	4000	3500 ⁽⁶⁾	2300 ⁽⁶⁾	1900 ⁽⁶⁾	32	
			4500	4000	3500	2550 ⁽⁶⁾	2100 ⁽⁶⁾	40	
			4500	4000	3500	3000 ⁽⁶⁾	2500 ⁽⁶⁾	64	
			4500	4000	3500	3000	2500	100	
Max. mechanical input speed ⁽⁴⁾	n_{1Limit}	rpm	14000	10000	8500	6500	6000		

(1) Ratios ($i=n_1/n_2$)
 (2) Number of stages
 (3) Permitted 1000 times
 (4) Application-specific speed configurations with NCP – www.neugart.com
 (5) See page 142 for the definition
 (6) Average thermal input speed at 50% T_{2N} and $S1$

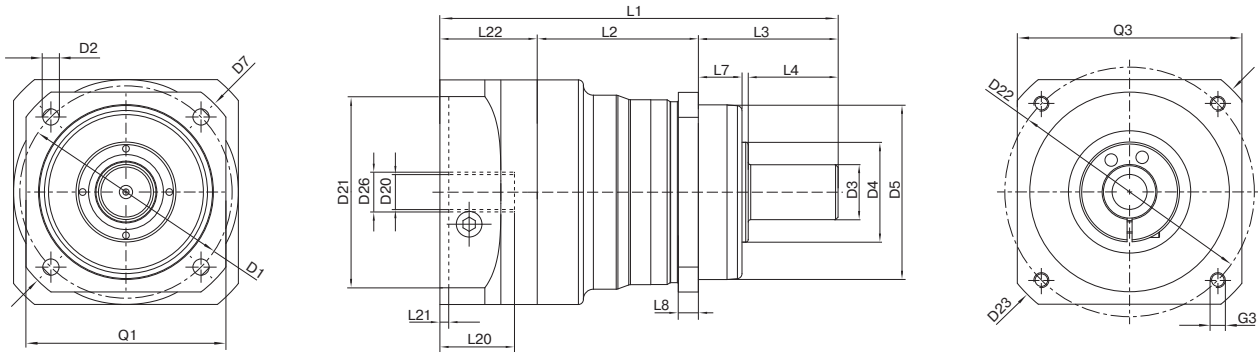

Drawing corresponds to a PLN090 / 1-stage / smooth output shaft / 19 mm clamping system / motor adaptation – 2-part – round universal flange / B5 flange type motor
 All other variants can be retrieved in the Tec Data Finder at www.neugart.com

Geometry ⁽¹⁾			PLN070	PLN090	PLN115	PLN142	PLN190	z ⁽²⁾	Code
Pitch circle diameter output	D1		68 - 75 (2.677 - 2.953)	85 (3.346)	120 (4.724)	165 (6.496)	215 (8.465)		
Mounting bore output	D2	4x	5.5 (0.217)	6.5 (0.256)	9.0 (0.354)	11.0 (0.433)	13.5 (0.531)		
Shaft diameter output	D3	k6	16 (0.630)	22 (0.866)	32 (1.260)	40 (1.575)	55 (2.165)		
Shaft collar output	D4		35 (1.378)	40 (1.575)	45 (1.772)	70 (2.756)	80 (3.150)		
Centering diameter output	D5	g7	60 (2.362)	70 (2.756)	90 (3.543)	130 (5.118)	160 (6.299)		
Diagonal dimension output	D7		92 (3.622)	100 (3.937)	140 (5.512)	185 (7.283)	240 (9.449)		
Flange cross section output	Q1	■	70 (2.756)	80 (3.150)	110 (4.331)	142 (5.591)	190 (7.480)		
Min. total length	L1		137.5 (5.413)	159.5 (6.280)	201 (7.913)	276 (10.866)	310.5 (12.224)	1	
			166.5 (6.555)	191.5 (7.539)	241 (9.488)	335 (13.189)	382.5 (15.059)	2	
Housing length	L2		59 (2.323)	64.5 (2.539)	61.5 (2.421)	91.5 (3.602)	116 (4.567)	1	
			88 (3.465)	96.5 (3.799)	101.5 (3.996)	150.5 (5.925)	188 (7.402)	2	
Centering depth output	L7		19 (0.748)	17.5 (0.689)	28 (1.102)	28 (1.102)	28 (1.102)		
Flange thickness output	L8		7 (0.276)	8 (0.315)	10 (0.394)	12 (0.472)	15 (0.591)		
Clamping system diameter input	D26		More information on page 131						
Motor shaft diameter j6/k6	D20		The dimensions vary with the motor/gearbox flange. The input flange dimensions can be retrieved for each specific motor in Tec Data Finder at www.neugart.com						
Max. permis. motor shaft length	L20								
Min. permis. motor shaft length									
Centering diameter input	D21								
Centering depth input	L21								
Pitch circle diameter input	D22								
Motor flange length	L22								
Diagonal dimension input	D23								
Mounting thread x depth	G3	4x							
Flange cross section input	Q3	■							
Output shaft with feather key (DIN 6885-1)			A 5x5x25	A 6x6x28	A 10x8x50	A 12x8x65	A 16x10x70		A
Feather key width (DIN 6885-1)	B1		5 (0.197)	6 (0.236)	10 (0.394)	12 (0.472)	16 (0.630)		
Shaft height including feather key (DIN 6885-1)	H1		18 (0.709)	24.5 (0.965)	35 (1.378)	43 (1.693)	59 (2.323)		
Shaft length output	L3		48 (1.890)	56 (2.205)	88 (3.465)	110 (4.331)	112 (4.409)		
Shaft length from shoulder	L4		28 (1.102)	36 (1.417)	58 (2.283)	80 (3.150)	82 (3.228)		
Feather key length	L5		25 (0.984)	28 (1.102)	50 (1.969)	65 (2.559)	70 (2.756)		
Distance from shaft end	L6		2 (0.079)	4 (0.157)	4 (0.157)	8 (0.315)	6 (0.236)		
Center hole (DIN 332, type DR)	Z		M5x12.5	M8x19	M12x28	M16x36	M20x42		
Smooth output shaft									B
Shaft length output	L3		48 (1.890)	56 (2.205)	88 (3.465)	110 (4.331)	112 (4.409)		
Shaft length from shoulder	L4		28 (1.102)	36 (1.417)	58 (2.283)	80 (3.150)	82 (3.228)		
Splined output shaft (DIN 5480)			W16x0.8x 18x6m	W22x1.25x 16x6m	W32x1.25x 24x6m	W40x2.0x 18x6m	W55x2.0x 26x6m		C
Width of gearing	L _v		15 (0.591)	15 (0.591)	15 (0.591)	20 (0.787)	22 (0.866)		
Shaft length output	L3		46 (1.811)	46 (1.811)	56 (2.205)	70 (2.756)	71.5 (2.815)		
Shaft length from shoulder	L4		26 (1.024)	26 (1.024)	26 (1.024)	40 (1.575)	41.5 (1.634)		
Center hole (DIN 332, type DR)	Z		M5x12.5	M8x19	M12x28	M16x36	M20x42		

⁽¹⁾ Dimensions in mm (in)
⁽²⁾ Number of stages