



WPLPE

The economical right angle planetary gearbox for particularly high forces – flexible installation options and lifetime lubrication

The **WPLPE** is the smart right angle solution from our Economy Line: Space-saving, and yet powerful at an attractive price. You install your drive elements directly on the output shaft and extract the maximum flexibility from your application.

Nominal output torque **5 - 195 Nm**

Torsional backlash **11 - 25 arcmin**

Tilting moment **26 - 168 Nm**

Protection class **IP54**

Frame sizes

50

70

90

120

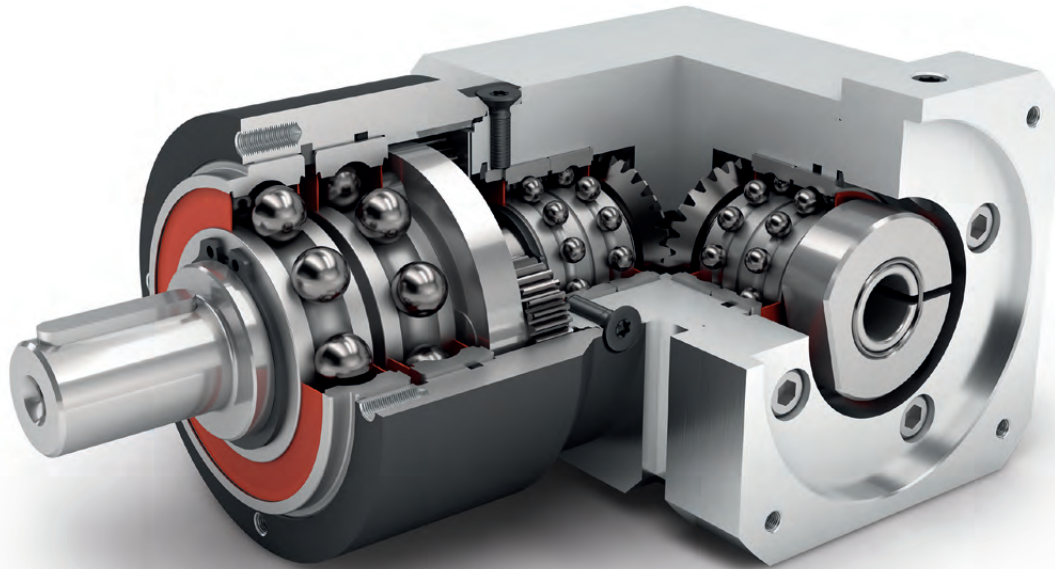

WPLPE



Economy Line



Right angle gearbox



Equidirectional rotation



Spur gear

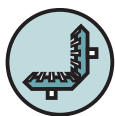

Bevel gear right angle stage

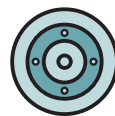

Round type output flange



Reinforced deep groove ball bearings



Planet carrier in disc design

Code	Gearbox characteristics			WPLPE050	WPLPE070	WPLPE090	WPLPE120	p ⁽¹⁾
	Service life (L _{10h})	t _L	h	20.000				
	Service life at T _{2N} × 0.88			30.000				
	Efficiency at full load ⁽²⁾	η	%	95				1
				94				2
	Min. operating temperature	T _{min}	°C	-25 (-13)				
	Max. operating temperature	T _{max}	(°F)	90 (194)				
	Protection class			IP54				
S	Standard lubrication			Grease (lifetime lubrication)				
F	Food grade lubrication			Grease (lifetime lubrication)				
L	Low temperature lubrication ⁽³⁾			Grease (lifetime lubrication)				
	Installation position			Any				
S	Standard backlash	j _t	arcmin	< 21	< 16	< 13	< 11	
				< 25	< 18	< 15	< 13	2
	Torsional stiffness ⁽²⁾	c _g	Nm/arcmin (lb _t .in/arcmin)	0.5 - 0.8 (4 - 7)	2.2 - 4.1 (19 - 36)	4.7 - 10.8 (42 - 96)	13.1 - 28.0 (116 - 248)	1
					0.7 - 1.0 (6 - 9)	3.3 - 5.3 (29 - 47)	9.0 - 14.1 (80 - 125)	19.5 - 38.5 (173 - 341)
	Gearbox weight	m _G	kg (lb _m)	0.85 (1.9)	2.3 (5.1)	5.3 (11.7)	13.5 (29.8)	1
					1.05 (2.3)	2.6 (5.7)	6.1 (13.5)	15.7 (34.6)
S	Standard surface			Housing: Steel – heat-treated and post-oxidized (black)				
	Running noise ⁽⁴⁾	Q _g	dB(A)	68	70	73	75	
	Max. bending moment based on the gearbox input flange ⁽⁵⁾	M _b	Nm (lb _t .in)	2 (18)	5 (44)	10.5 (93)	26 (230)	

Output shaft loads			WPLPE050	WPLPE070	WPLPE090	WPLPE120	p ⁽¹⁾
Radial force for 20,000 h ⁽⁶⁾⁽⁷⁾	F _{r,20.000h}	N (lb _f)	800 (180)	1050 (236)	1900 (427)	2500 (562)	
Axial force for 20,000 h ⁽⁶⁾⁽⁷⁾	F _{a,20.000h}		1000 (225)	1350 (303)	2000 (450)	4000 (899)	
Radial force for 30,000 h ⁽⁶⁾⁽⁷⁾	F _{r,30.000h}		700 (157)	900 (202)	1700 (382)	2150 (483)	
Axial force for 30,000 h ⁽⁶⁾⁽⁷⁾	F _{a,30.000h}		800 (180)	1000 (225)	1500 (337)	3000 (674)	
Maximum radial force ⁽⁷⁾⁽⁸⁾	F _{r,Stat}		1300 (292)	1650 (371)	3100 (697)	4000 (899)	
Maximum axial force ⁽⁷⁾⁽⁸⁾	F _{a,Stat}		1000 (225)	2100 (472)	3800 (854)	5900 (1326)	
Tilting moment for 20,000 h ⁽⁶⁾⁽⁸⁾	M _{K,20.000h}	Nm (lb _t .in)	26 (230)	42 (372)	99 (876)	168 (1487)	
Tilting moment for 30,000 h ⁽⁶⁾⁽⁸⁾	M _{K,30.000h}		22 (195)	36 (319)	89 (788)	144 (1275)	

Moment of inertia			WPLPE050	WPLPE070	WPLPE090	WPLPE120	p ⁽¹⁾
Mass moment of inertia ⁽²⁾	J	kgcm ² (lb _t .in.s ² 10 ⁻⁴)	0.032 - 0.052 (0.283 - 0.460)	0.218 - 0.329 (1.929 - 2.912)	0.925 - 1.408 (8.187 - 12.462)	1.861 - 3.248 (16.471 - 28.747)	1
			0.031 - 0.049 (0.274 - 0.434)	0.218 - 0.326 (1.929 - 2.885)	0.907 - 1.245 (8.028 - 11.019)	1.818 - 2.818 (16.091 - 24.941)	2

(1) Number of stages

(2) The ratio-dependent values can be retrieved in Tec Data Finder – www.neugart.com

(3) T_{min} = -40°C. Optimal operating temperature max. 50°C

(4) Sound pressure level from 1 m, measured on input running at n₁=3000 rpm no load; i=5

(5) Max. motor weight* in kg = 0.2 × M_b / motor length in m

* with symmetrically distributed motor weight

* with horizontal and stationary mounting

(6) These values are based on an output shaft speed of n₂=100 rpm

(7) Based on center of output shaft

(8) Other (sometimes higher) values following changes to T_{2N}, F_r, F_a, cycle, and service life of bearing. Application specific configuration with NCP – www.neugart.com

Output torques			WPLPE050	WPLPE070	WPLPE090	WPLPE120	i ⁽¹⁾	p ⁽²⁾
Nominal output torque ⁽³⁾⁽⁴⁾	T _{2N}	Nm (lb _r .in)	4.5 (40)	14 (124)	40 (354) ⁽⁵⁾	80 (708) ⁽⁵⁾	3	1
			6 (53)	19 (168)	53 (469) ⁽⁵⁾	105 (929) ⁽⁵⁾	4	
			7.5 (66)	24 (212)	67 (593) ⁽⁵⁾	130 (1151) ⁽⁵⁾	5	
			8.5 (75)	25 (221)	65 (575)	135 (1195)	7	
			6 (53)	18 (159)	50 (443)	120 (1062)	8	
			5 (44)	15 (133)	38 (336)	95 (841)	10	
			12 (106)	33 (292)	97 (859)	157 (1390)	9	
			15 (133)	33 (292)	90 (797)	195 (1726)	12	
		2	13 (115)	33 (292)	82 (726)	172 (1522)	15	
			15 (133)	33 (292)	90 (797)	195 (1726)	16	
			15 (133)	33 (292)	90 (797)	195 (1726)	20	
			13 (115)	30 (266)	82 (726)	172 (1522)	25	
			15 (133)	33 (292)	90 (797)	195 (1726)	32	
			13 (115)	30 (266)	82 (726)	172 (1522)	40	
			7.5 (66)	18 (159)	50 (443)	120 (1062)	64	
			5 (44)	15 (133)	38 (336)	95 (841)	100	
Max. output torque ⁽⁴⁾⁽⁶⁾	T _{2max}	Nm (lb _r .in)	7 (62)	22 (195)	64 (566)	128 (1133)	3	1
			10 (89)	30 (266)	85 (752)	168 (1487)	4	
			12 (106)	38 (336)	107 (947)	208 (1841)	5	
			13.5 (119)	40 (354)	104 (920)	216 (1912)	7	
			10 (89)	29 (257)	80 (708)	192 (1699)	8	
			8 (71)	24 (212)	61 (540)	152 (1345)	10	
			19 (168)	53 (469)	155 (1372)	251 (2222)	9	
			24 (212)	53 (469)	144 (1275)	312 (2761)	12	
		2	21 (186)	53 (469)	131 (1159)	275 (2434)	15	
			24 (212)	53 (469)	144 (1275)	312 (2761)	16	
			24 (212)	53 (469)	144 (1275)	312 (2761)	20	
			21 (186)	48 (425)	131 (1159)	275 (2434)	25	
			24 (212)	53 (469)	144 (1275)	312 (2761)	32	
			21 (186)	48 (425)	131 (1159)	275 (2434)	40	
			12 (106)	29 (257)	80 (708)	192 (1699)	64	
			8 (71)	24 (212)	61 (540)	152 (1345)	100	

WPLPE

⁽¹⁾ Ratios (i=n₁/n₂)
⁽²⁾ Number of stages
⁽³⁾ Application specific configuration with NCP – www.neugart.com
⁽⁴⁾ Values for feather key (code "A"): for repeated load
⁽⁵⁾ Different service life: 10,000 h at T_{2N}
⁽⁶⁾ 30,000 rotations of the output shaft permitted; see page 142

Output torques			WPLPE050	WPLPE070	WPLPE090	WPLPE120	i ⁽¹⁾	p ⁽²⁾
Emergency stop torque ⁽³⁾	T _{2Stop}	Nm (lb _f .in)	22.5 (199)	66 (584)	180 (1593)	360 (3186)	3	1
			28 (248)	86 (761)	240 (2124)	474 (4195)	4	
			35 (310)	80 (708)	220 (1947)	500 (4425)	5	
			26 (230)	80 (708)	178 (1575)	340 (3009)	7	
			27 (239)	80 (708)	190 (1682)	380 (3363)	8	
			25 (221)	70 (620)	170 (1505)	430 (3806)	10	
		33 (292)	88 (779)	260 (2301)	500 (4425)	9	2	
		40 (354)	88 (779)	240 (2124)	520 (4602)	12		
		36 (319)	88 (779)	220 (1947)	500 (4425)	15		
		40 (354)	88 (779)	240 (2124)	520 (4602)	16		
		40 (354)	88 (779)	240 (2124)	520 (4602)	20		
		36 (319)	80 (708)	220 (1947)	500 (4425)	25		
		40 (354)	88 (779)	240 (2124)	520 (4602)	32		
		36 (319)	80 (708)	220 (1947)	500 (4425)	40		
		27 (239)	80 (708)	190 (1682)	380 (3363)	64		
		27 (239)	80 (708)	170 (1505)	430 (3806)	100		

Input speeds			WPLPE050	WPLPE070	WPLPE090	WPLPE120	i ⁽¹⁾	p ⁽²⁾
Average thermal input speed at T _{2N} and S1 ⁽⁴⁾⁽⁵⁾	n _{1N}	rpm	5000	4200 ⁽⁶⁾	3000 ⁽⁶⁾	2350 ⁽⁶⁾	3	1
			5000	4500 ⁽⁶⁾	3150 ⁽⁶⁾	2450 ⁽⁶⁾	4	
			5000	4500 ⁽⁶⁾	3250 ⁽⁶⁾	2600 ⁽⁶⁾	5	
			5000	4500 ⁽⁶⁾	3950 ⁽⁶⁾	3100 ⁽⁶⁾	7	
			5000	4500	4000 ⁽⁶⁾	3450 ⁽⁶⁾	8	
			5000	4500	4000	3500 ⁽⁶⁾	10	
			5000	4500 ⁽⁶⁾	3500 ⁽⁶⁾	2950 ⁽⁶⁾	9	2
			5000	4500	4000 ⁽⁶⁾	3050 ⁽⁶⁾	12	
			5000	4500	4000 ⁽⁶⁾	3450 ⁽⁶⁾	15	
			5000	4500	4000 ⁽⁶⁾	3450 ⁽⁶⁾	16	
			5000	4500	4000 ⁽⁶⁾	3500 ⁽⁶⁾	20	
			5000	4500	4000	3500 ⁽⁶⁾	25	
			5000	4500	4000	3500	32	
			5000	4500	4000	3500	40	
			5000	4500	4000	3500	64	
			5000	4500	4000	3500	100	
			Max. mechanical input speed ⁽⁴⁾	n _{1Limit}	rpm	18000	13000	

(1) Ratios (i=n₁/n₂)
 (2) Number of stages
 (3) Permitted 1000 times
 (4) Application-specific speed configurations with NCP – www.neugart.com
 (5) See page 142 for the definition
 (6) Average thermal input speed at 50% T_{2N} and S1

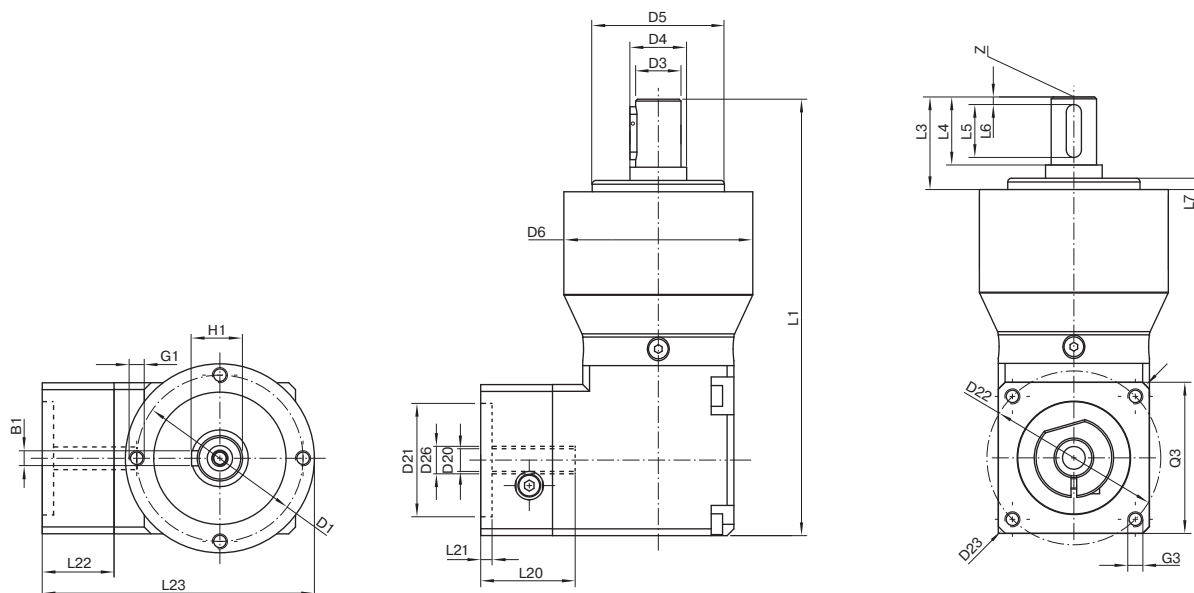

Drawing corresponds to a WPLPE090 / 1-stage / output shaft with feather key / 19 mm clamping system / motor adaptation – 2-part – square universal flange / B5 flange type motor
 All other variants can be retrieved in the Tec Data Finder at www.neugart.com

Geometry ⁽¹⁾			WPLPE050	WPLPE070	WPLPE090	WPLPE120	p ⁽²⁾	Code
Pitch circle diameter output	D1		44 (1.732)	62 (2.441)	80 (3.150)	108 (4.252)		
Shaft diameter output	D3	k7	12 (0.472)	16 (0.630)	22 (0.866)	32 (1.260)		
Shaft collar output	D4		15 (0.591)	30 (1.181)	35 (1.378)	50 (1.969)		
Centering diameter output	D5	h7	35 (1.378)	52 (2.047)	68 (2.677)	90 (3.543)		
Housing diameter	D6		50 (1.969)	70 (2.756)	90 (3.543)	120 (4.724)		
Mounting thread x depth	G1	4x	M4x8	M5x8	M6x9	M8x20		
Total length	L1		115.5 (4.547)	152.5 (6.004)	197.5 (7.776)	265 (10.433)	1	
			128 (5.039)	165.5 (6.516)	215.5 (8.484)	292.5 (11.516)	2	
Shaft length output	L3		24.5 (0.965)	36 (1.417)	46 (1.811)	68 (2.677)		
Centering depth output	L7		3 (0.118)	3 (0.118)	4 (0.157)	5 (0.197)		
Min. overall height	L23		67 (2.638)	91 (3.563)	115 (4.528)	148 (5.827)		
Clamping system diameter input	D26		More information on page 131					
Motor shaft diameter j6/k6	D20		The dimensions vary with the motor/gearbox flange. The input flange dimensions can be retrieved for each specific motor in Tec Data Finder at www.neugart.com					
Max. permis. motor shaft length	L20							
Min. permis. motor shaft length								
Centering diameter input	D21							
Centering depth input	L21							
Pitch circle diameter input	D22							
Motor flange length	L22							
Diagonal dimension input	D23							
Mounting thread x depth	G3	4x						
Flange cross section input	Q3	■						
Output shaft with feather key (DIN 6885-1)			A 4x4x14	A 5x5x25	A 6x6x32	A 10x8x50		A
Feather key width (DIN 6885-1)	B1		4 (0.157)	5 (0.197)	6 (0.236)	10 (0.394)		
Shaft height including feather key (DIN 6885-1)	H1		13.5 (0.531)	18 (0.709)	24.5 (0.965)	35 (1.378)		
Shaft length from shoulder	L4		18 (0.709)	28 (1.102)	36 (1.417)	58 (2.283)		
Feather key length	L5		14 (0.551)	25 (0.984)	32 (1.260)	50 (1.969)		
Distance from shaft end	L6		2 (0.079)	2 (0.079)	2 (0.079)	4 (0.157)		
Center hole (DIN 332, type DR)	Z		M4x10	M5x12.5	M8x19	M12x28		
Smooth output shaft								B
Shaft length from shoulder	L4		18 (0.709)	28 (1.102)	36 (1.417)	58 (2.283)		

⁽¹⁾ Dimensions in mm (in)

⁽²⁾ Number of stages